

Installation Note

Noise Figure Measurement Capability Upgrade Kit

To Upgrade PNA N5242A Options 419 and 423 to include Option 029

Upgrade Kit Order Number: N5242AU- 929



Agilent Kit Number: N5242-60106

Agilent Document Number: N5242-90010

Printed in USA November 2008

Supersedes: October 2007

© Agilent Technologies, Inc. 2007-2008



N5242-90010

WARRANTY STATEMENT

THE MATERIAL CONTAINED IN THIS DOCUMENT IS PROVIDED “AS IS,” AND IS SUBJECT TO BEING CHANGED, WITHOUT NOTICE, IN FUTURE EDITIONS. FURTHER, TO THE MAXIMUM EXTENT PERMITTED BY APPLICABLE LAW, AGILENT DISCLAIMS ALL WARRANTIES, EITHER EXPRESS OR IMPLIED WITH REGARD TO THIS MANUAL AND ANY INFORMATION CONTAINED HEREIN, INCLUDING BUT NOT LIMITED TO THE IMPLIED WARRANTIES OF MERCHANTABILITY AND FITNESS FOR A PARTICULAR PURPOSE. AGILENT SHALL NOT BE LIABLE FOR ERRORS OR FOR INCIDENTAL OR CONSEQUENTIAL DAMAGES IN CONNECTION WITH THE FURNISHING, USE, OR PERFORMANCE OF THIS DOCUMENT OR ANY INFORMATION CONTAINED HEREIN. SHOULD AGILENT AND THE USER HAVE A SEPARATE WRITTEN AGREEMENT WITH WARRANTY TERMS COVERING THE MATERIAL IN THIS DOCUMENT THAT CONFLICT WITH THESE TERMS, THE WARRANTY TERMS IN THE SEPARATE AGREEMENT WILL CONTROL.

DFARS/Restricted Rights Notice

If software is for use in the performance of a U.S. Government prime contract or subcontract, Software is delivered and licensed as “Commercial computer software” as defined in DFAR 252.227-7014 (June 1995), or as a “commercial item” as defined in FAR 2.101(a) or as “Restricted computer software” as defined in FAR 52.227-19 (June 1987) or any equivalent agency regulation or contract clause. Use, duplication or disclosure of Software is subject to Agilent Technologies’ standard commercial license terms, and non-DOD Departments and Agencies of the U.S. Government will receive no greater than Restricted Rights as defined in FAR 52.227-19(c)(1-2) (June 1987). U.S. Government users will receive no greater than Limited Rights as defined in FAR 52.227-14 (June 1987) or DFAR 252.227-7015 (b)(2) (November 1995), as applicable in any technical data.

Safety Notes

The following safety notes are used throughout this document. Familiarize yourself with each of these notes and its meaning before performing any of the procedures in this document.

WARNING	Warning denotes a hazard. It calls attention to a procedure which, if not correctly performed or adhered to, could result in injury or loss of life. Do not proceed beyond a warning note until the indicated conditions are fully understood and met.
----------------	---

CAUTION	Caution denotes a hazard. It calls attention to a procedure that, if not correctly performed or adhered to, could result in damage to or destruction of the instrument. Do not proceed beyond a caution sign until the indicated conditions are fully understood and met.
----------------	---

Getting Assistance from Agilent

By internet, phone, or fax, get assistance with all your test and measurement needs.

Contacting Agilent

Assistance with test and measurements needs and information on finding a local Agilent office are available on the Web at:

<http://www.agilent.com/find/assist>

If you do not have access to the Internet, please contact your Agilent field engineer.

NOTE In any correspondence or telephone conversation, refer to the Agilent product by its model number and full serial number. With this information, the Agilent representative can determine whether your product is still within its warranty period.

Description of the Upgrade

This upgrade adds noise figure measurement capability to your Option 419 or 423 4-port analyzer by adding Option 029 which includes:

- a noise downconverter and noise receiver
- a bypass switch to ports 1 and 2

About Installing the Upgrade

Products affected	N5242A Option 419 or 423
Installation to be performed by	Agilent service center or personnel qualified by Agilent
Estimated installation time	5.0 hours
Estimated adjustment time	0.5 hours
Estimated full instrument calibration time	4.5 hours

Items Included in the Upgrade Kit

Check the contents of your kit against the following list. If any part is missing or damaged, contact Agilent Technologies. Refer to [“Getting Assistance from Agilent” on page 3](#).

Table 1 Contents of Upgrade Kit N5242-60106

Ref Desig.	Description	Qty	Part Number
	Installation note (this document)	1	N5242-90010
	Entitlement certificate	1	5964-5145
Assemblies			
A7	Noise receiver board	1	N5142-60098
A16	Power supply	1	0950-4900
A52	Bypass switch, port 1	1	N1811-60008
A53	Bypass switch, port 2	1	N1811-60006
A54	Bridge	1	5087-7315
A55	Noise downconverter	1	5087-7316
Hardware/Miscellaneous			
	Switch/attenuator bracket	2	N5242-00031
	Bias tee bracket	2	N5242-00032
	Machine screw, M3.0 x 18, pan head (to attach A52 and A53 to switch brackets)	4	0515-0666
	Machine screw, M3.0 x 6, pan head (to attach bias tee brackets)	4	0515-0430
	Machine screw, M3.0 x 20, pan head (to attach A54 to side frame)	1	0515-1410
	Hex nut with lock washer (for screw 0515-1410; to attach A54 to side frame)	1	0535-0031
	Machine screw, M3.0 x 10, pan head (to attach A55 to side frame)	3	0515-0374
	Lower front panel overlay	1	N5242-80012
Cables (listed in the order in which they are installed)			
W26	RF cable, A32 port 2 coupler to front-panel Port 2 CPLR ARM	1	N5242-20044
W135	RF cable, front-panel Port 2 RCVR B IN to A45 port 2 receiver attenuator	1	N5242-20073
W128	RF cable, A53 port 2 bypass switch to front-panel Port 2 SOURCE OUT	1	N5242-20134
W127	RF cable, A37 port 2 source attenuator to A53 port 2 bypass switch	1	N5242-20116
W130	RF cable, A52 port 2 bypass switch to A54 port 2 bridge	1	N5242-20133
W129	RF cable, A53 port 2 bypass switch to A54 port 2 bridge	1	N5242-20117
W125	RF cable, A52 port 1 bypass switch to A38 port 1 bias tee	1	N5242-20126
W152	RF cable, A52 port 1 bypass switch to A29 port 1 coupler	1	N5242-20144
W14	RF cable, A29 port 1 coupler to front-panel Port 1 CPLR ARM	1	N5242-20040
W132	RF cable, front-panel Port 1 RCVR A IN to A42 port 1 receiver attenuator	1	N5242-20072

Table 1 Contents of Upgrade Kit N5242-60106

Ref Desig.	Description	Qty	Part Number
W124	RF cable, front-panel Port 1 CPLR THRU to A52 port 1 bypass switch	1	E8356-20125
W123	RF cable, A52 port 1 bypass switch to front-panel Port 1 SOURCE OUT	1	N5242-20127
W122	RF cable, A34 port 1 source attenuator to A52 port 1 bypass switch	1	N5242-20128
W126	RF cable, A28 port 2 bridge to A37 port 2 source attenuator	1	N5242-20066
W137	RF cable, A28 port 2 bridge to front-panel REF 2 SOURCE OUT	1	N5242-20074
W121	RF cable, A25 port 1 bridge to A34 port 1 source attenuator	1	N5242-20067
W136	RF cable, A33 reference mixer switch to A23 mixer brick (R1)	1	N5242-20068
W133	RF cable, A42 port 1 receiver attenuator to A23 mixer brick (A)	1	N5242-20069
W134	RF cable, A45 port 2 receiver attenuator to A23 mixer brick (B)	1	N5242-20070
W138	RF cable, front-panel REF 2 RCVR R2 IN to A23 mixer brick (R2)	1	N5242-20075
W140	RF cable, A24 mixer brick to A55 noise downconverter	1	N5242-20118
W143	RF cable, A55 noise downconverter to A7 noise receiver board RF	1	N5242-20130
W141	RF cable, A55 noise downconverter to A7 noise receiver board LO	1	N5242-20129
W142	RF cable, A55 noise downconverter J4 to A7 noise receiver board P2	1	N5242-60041
	Ribbon cable, A19 test set motherboard J548 to A55 noise downconverter J1	1	N5242-60033

Installation Procedure for the Upgrade

The network analyzer must be in proper working condition prior to installing this option. Any necessary repairs must be made before proceeding with this installation.

WARNING **This installation requires the removal of the analyzer's protective outer covers. The analyzer must be powered down and disconnected from the mains supply before performing this procedure.**

Electrostatic Discharge Protection

Protection against electrostatic discharge (ESD) is essential while removing or connecting cables or assemblies within the network analyzer.

Static electricity can build up on your body and can easily damage sensitive internal circuit elements when discharged. Static discharges too small to be felt can cause permanent damage. To prevent damage to the instrument:

- *always* have a grounded, conductive table mat in front of your test equipment.
- *always* wear a grounded wrist strap, connected to a grounded conductive table mat, having a 1 M Ω resistor in series with it, when handling components and assemblies or when making connections.
- *always* wear a heel strap when working in an area with a conductive floor. If you are uncertain about the conductivity of your floor, wear a heel strap.
- *always* ground yourself before you clean, inspect, or make a connection to a static-sensitive device or test port. You can, for example, grasp the grounded outer shell of the test port or cable connector briefly.

Figure 1 shows a typical ESD protection setup using a grounded mat and wrist strap. Refer to “Tools and Equipment Required for the Installation” on page 7 for part numbers.

Figure 1 ESD Protection Setup

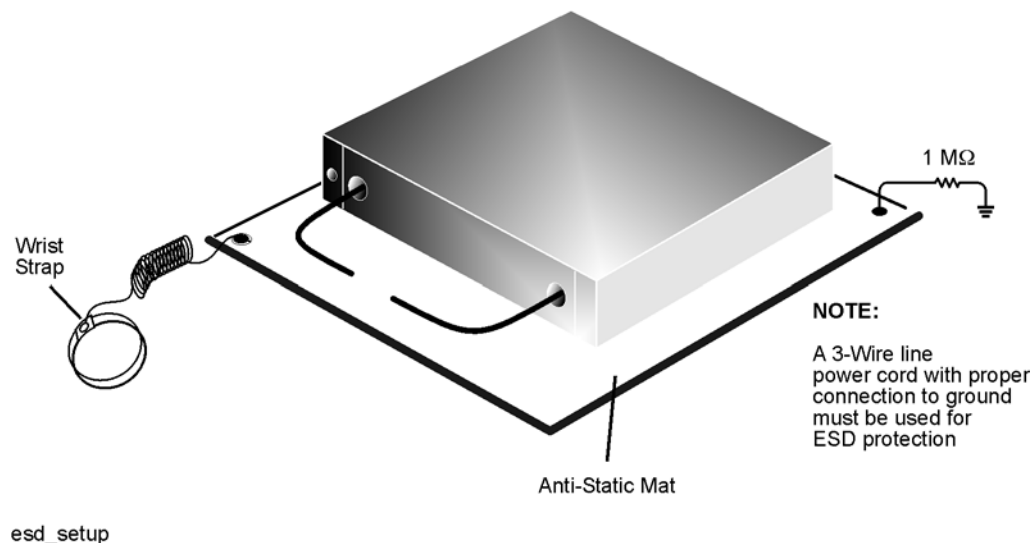

Tools and Equipment Required for the Installation

Description	Qty	Part Number
T-10 TORX driver (set to 9 in-lbs)	1	N/A
T-20 TORX driver (set to 21 in-lbs)	1	N/A
5/16-in torque wrench (set to 10 in-lbs)	1	N/A
5/16-in torque wrench (set to 21 in-lbs)	1	N/A

CAUTION Use a 5/16-in torque wrench set to 10 in-lbs on all cable connections except the front and rear panel cable connectors. Torque these connections to 21 in-lb.

ESD Equipment and Supplies Required for the Installation

Description	Agilent Part Number
ESD grounding wrist strap	9300-1367
5-ft grounding cord for wrist strap	9300-0980
2 x 4 ft conductive table mat and 15-ft grounding wire	9300-0797
ESD heel strap (for use with conductive floors)	9300-1308

Overview of the Installation Procedure

Step 1: Obtain a Keyword.

Step 2. Remove the Outer Cover.

Step 3. Remove the Inner Cover.

Step 4. Remove the Front Panel Assembly.

Step 5. Remove the Existing Test Set Cables.

Step 6. Remove the Existing Attenuators and Brackets.

Step 7. Assemble the Old Attenuators and the New A52 and A53 Bypass Switches onto the New Brackets.

Step 8. Install the New Brackets, with the Old Attenuators and the New A52 and A53 Bypass Switches, into the Analyzer.

Step 9. Assemble and Install the A54 Bridge and A55 Noise Downconverter.

Step 10. Install the A7 Noise Receiver Board.

Step 11. Install the New Test Set Cables.

Step 13. Replace the Lower Front Panel Overlay.

Step 12. Replace the A16 Power Supply (If Necessary).

Step 14. Reinstall the Front Panel Assembly and Front Panel Jumpers.

Step 15. Reinstall the Inner Cover.

Step 16. Reinstall the Outer Cover.

Step 17. Enable Option 029.

Step 18. Perform Post-Upgrade Adjustments and Calibration.

Step 1: Obtain a Keyword

Follow the instructions on the keyword Entitlement Certificate supplied to obtain a keyword for installation of this upgrade.

Once the keyword has been obtained, you can proceed with the installation.

Step 2. Remove the Outer Cover

CAUTION This procedure is best performed with the analyzer resting on its front handles in the vertical position. *Do not place the analyzer on its front panel without the handles.* This will damage the front panel assemblies.

Refer to [Figure 2](#) for this step of the procedure.

1. Disconnect the power cord (if it has not already been disconnected).
2. Remove the strap handles (item ①) by loosening the screws (item ②), with a T-20 TORX driver, on both ends until the handle is free of the analyzer.
3. Remove the foot locks (item ③) from the four bottom feet (item ④) and then remove the four bottom feet from the outer cover.
4. Remove the four rear panel feet (item ⑤) by removing the center screws (item ⑥) with a T-20 TORX driver.
5. Slide the outer cover toward the rear of the analyzer and remove it.

Figure 2 Outer Cover Removal

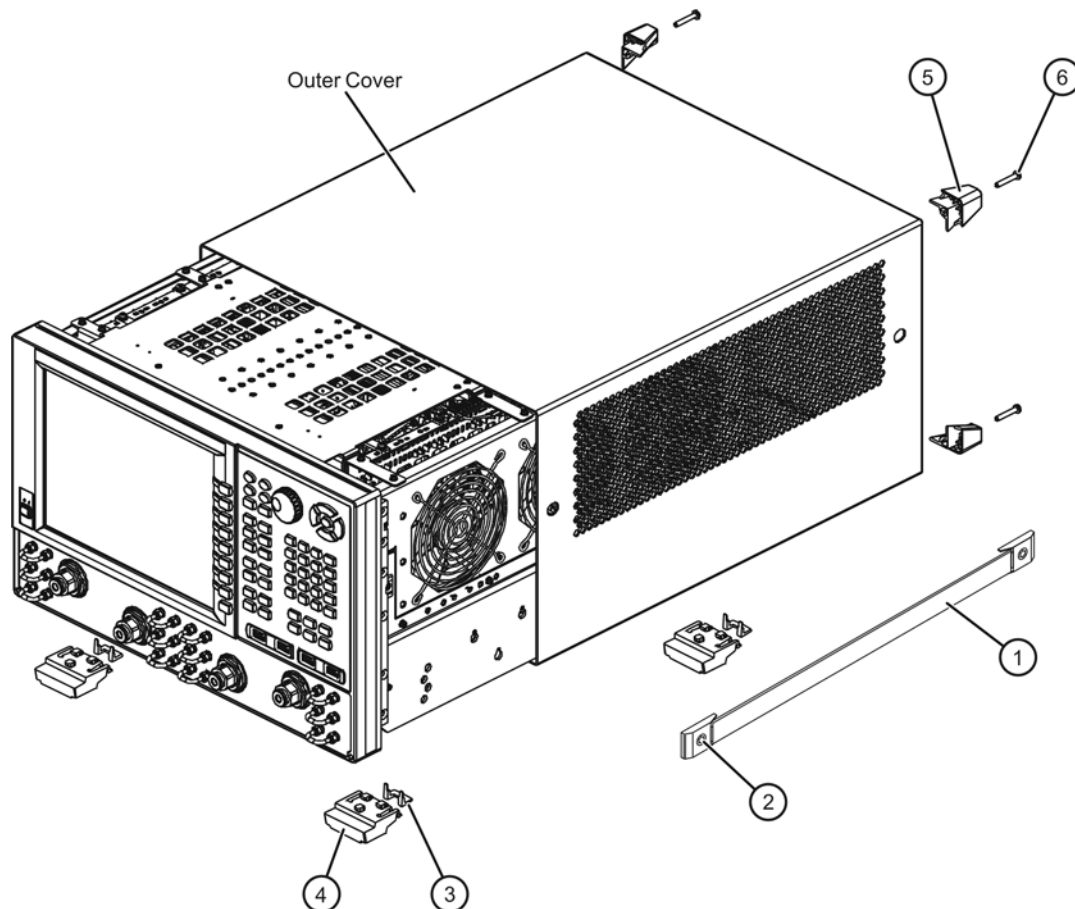

n5242_004_01

Step 3. Remove the Inner Cover

Refer to [Figure 3](#) for this step of the procedure.

1. With a T-10 TORX driver, remove the 12 pan head screws (item ①).
2. With a T-10 TORX driver, remove the 9 flat head screws (item ②).
3. Lift off the cover.

Figure 3 Inner Cover Removal

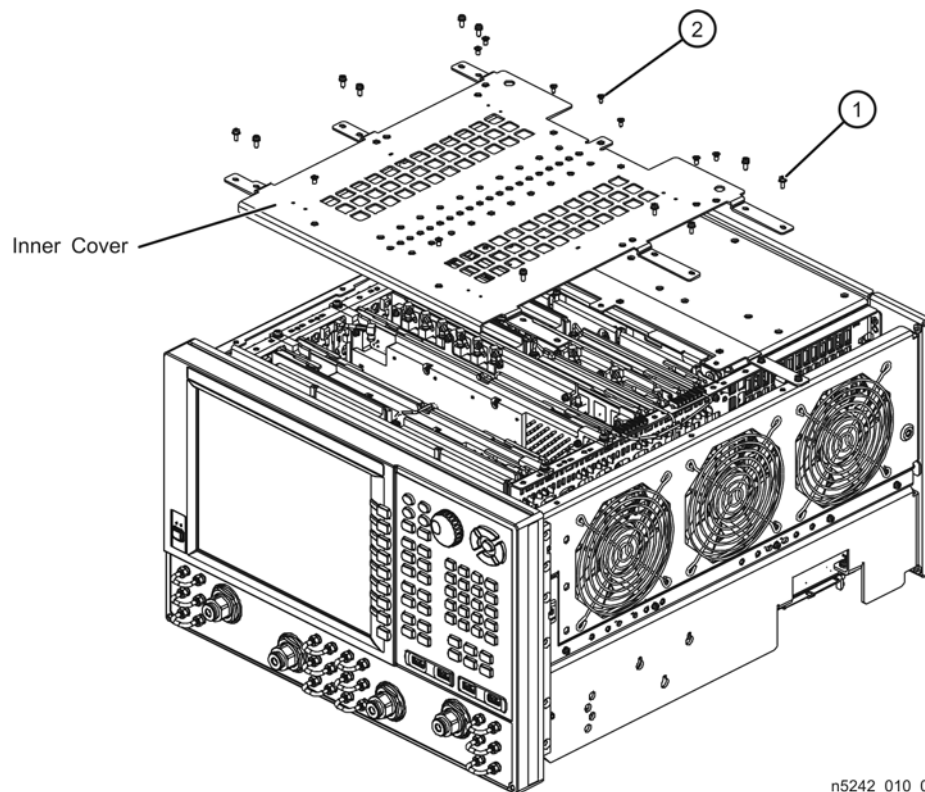

Step 4. Remove the Front Panel Assembly

Refer to [Figure 4](#) for this step of the procedure.

1. With a 5/16-in wrench, remove all front panel jumpers (item ①).
2. With a T-10 TORX driver, remove the screws (item ②) from the sides of the frame.

CAUTION Before removing the front panel from the analyzer, lift and support the front of the analyzer chassis.

3. Slide the front panel over the test port connectors.
4. Disconnect the front panel interface ribbon cable (item ③). The front panel is now free from the analyzer.

Figure 4 Front Panel Assembly Removal

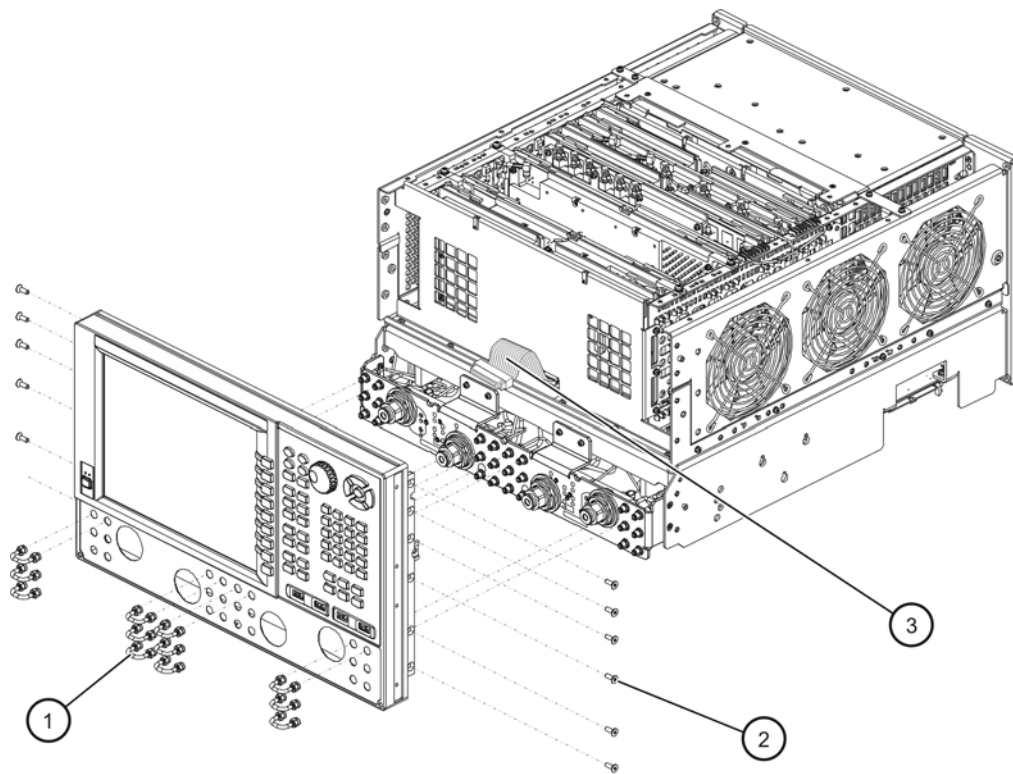

n5242_010_02

Step 5. Remove the Existing Test Set Cables

Refer to [Figure 5](#) for this step of the procedure. Although only Option 419 is shown in the illustration, Option 423 is similar in appearance.

1. Place the analyzer bottom-side up on a flat surface.
2. Remove the following cables in the order listed. Discard these cables; they will not be reused.
 - W40 Front-panel REF 2 RCVR R2 IN to A23 mixer brick (R2)
 - W94 A45 port 2 receiver attenuator to A23 mixer brick (B)
 - W88 A42 port 1 receiver attenuator to A23 mixer brick (A)
 - W37 A33 reference mixer switch to A23 mixer brick (R1)
 - W71 A25 port 1 bridge to A34 port 1 source attenuator
 - W25 A28 port 2 bridge to front-panel REF 2 SOURCE OUT
 - W83 A28 port 2 bridge to A37 port 2 source attenuator
 - W72 A34 port 1 source attenuator to front-panel Port 1 SOURCE OUT
 - W14 A29 port 1 coupler to front-panel Port 1 CPLR ARM

If bias tee option is installed:

- W73 Front-panel Port 1 CPLR THRU to A38 port 1 bias tee

If bias tee option is not installed:

- W114 Front-panel Port 1 CPLR THRU to A29 port 1 coupler
 - W87 Front-panel Port 1 RCVR A IN to A42 port 2 receiver attenuator
 - W84A37 port 2 source attenuator to front-panel Port 2 SOURCE OUT
 - W93Front-panel Port 2 RCVR B IN to A45 port 2 receiver attenuator
 - W26A32 port 2 coupler to front-panel Port 2 CPLR ARM
3. Disconnect the ribbon cable from the port 1 and port 2 step attenuator connectors. It is not necessary to disconnect these ribbon cables from the A19 test set motherboard; connector designations are given here for reference only.
 - a. Item ① connects between the A42 port 1 receiver attenuator and A19 test set motherboard connector J205.
 - b. Item ② connects between the A34 port 1 source attenuator and A19 test set motherboard connector J201.
 - c. Item ③ connects between the A45 port 2 receiver attenuator and A19 test set motherboard connector J208.
 - d. Item ④ connects between the A37 port 2 source attenuator and A19 test set motherboard connector J204.
 4. Remove the termination (item ⑤) from the A24 mixer brick. This termination will not be reinstalled.

Figure 5 Existing Test Set Cables Removal

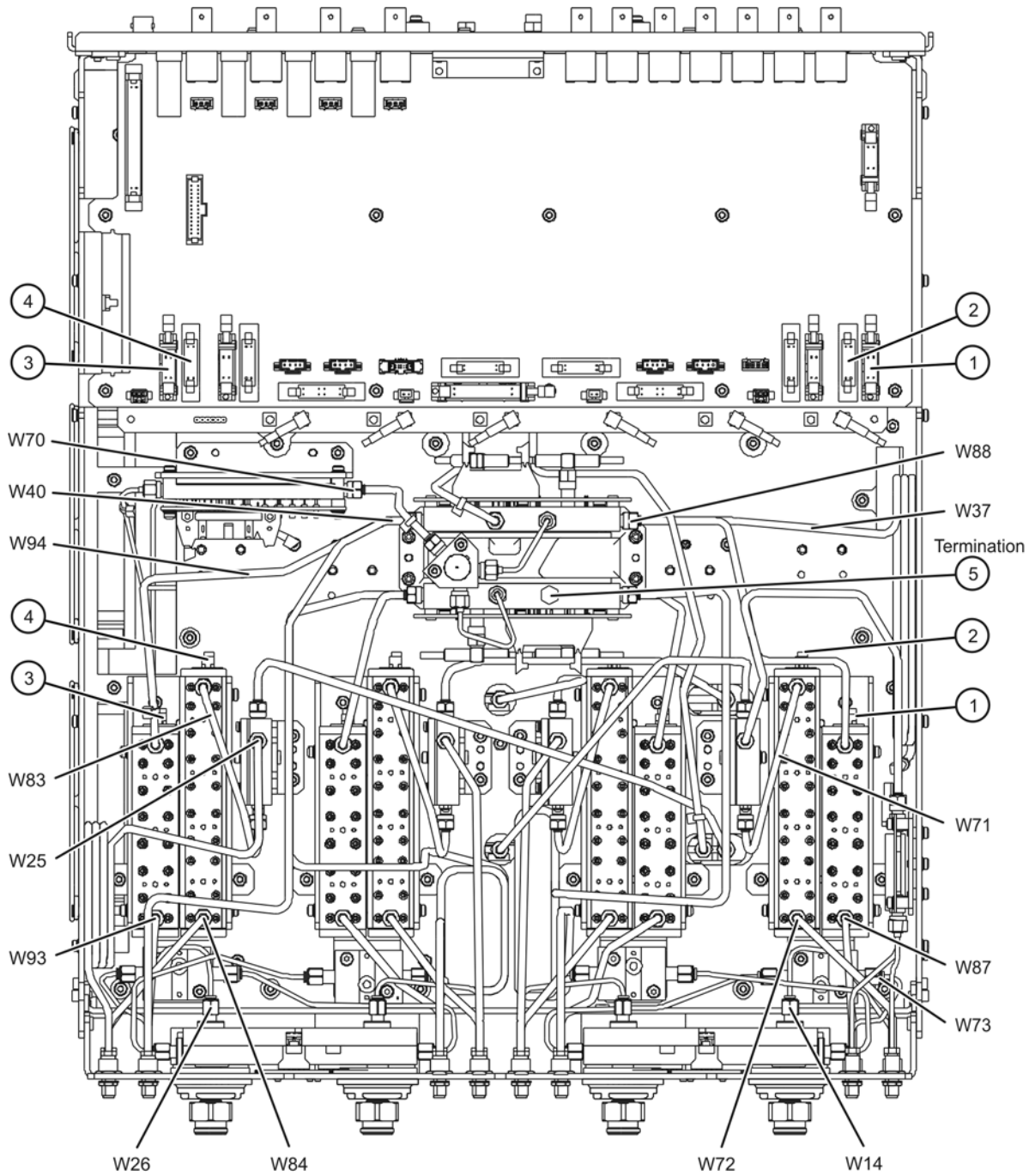

n5242_010_03

Step 6. Remove the Existing Attenuators and Brackets

Refer to [Figure 6](#) for this step of the procedure. Although only Option 419 is shown in the illustration, Option 423 is similar in appearance.

1. Place the analyzer bottom-side up on a flat surface.

If bias tee option is installed:

2. Disconnect the following cables from the bias tees and loosen the connectors at the other end of each of these cables. Pull the connectors away from the bias tees. Be careful not to over bend these cables. If necessary, remove the cables completely from the analyzer.

- W85 Front-panel Port 2 CPLR THRU to A41 port 2 bias tee
- W86 A41 port 2 bias tee to A32 port 2 coupler
- W74 A38 port 1 bias tee to A29 port 1 coupler

3. Remove two screws (item ①) from each bias tee and lift the bias tees away from the bracket and set them aside, with the cables still attached, for reinstallation later.

4. Remove three screws (item ②) from each attenuator bracket.

5. Remove the attenuator brackets, with the attenuators still attached, from the analyzer.

6. If it is necessary to remove any other cables from the analyzer to facilitate removal of the attenuators and bias tees brackets, be sure to note their locations and set them aside for reinstallation later.

Figure 6 Existing Attenuators and Brackets Removal

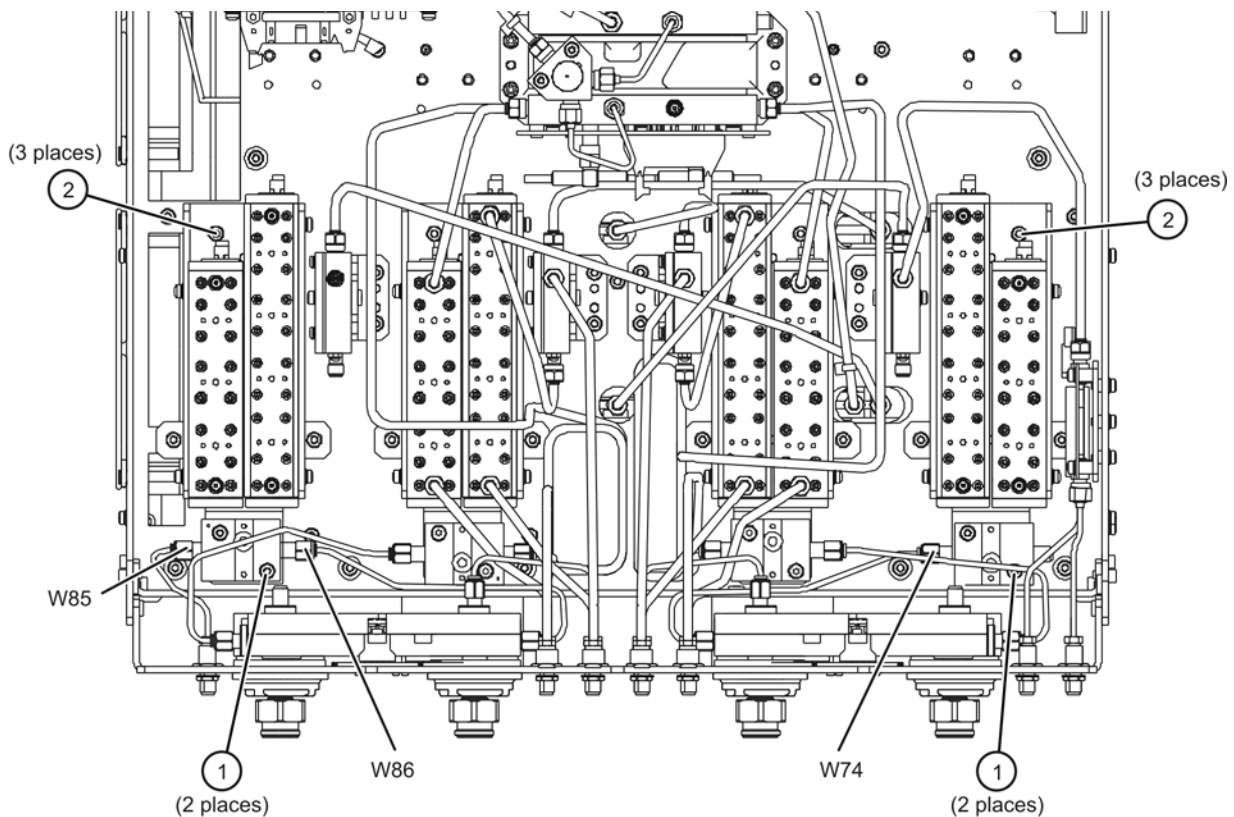

n5242_010_04

Step 7. Assemble the Old Attenuators and the New A52 and A53 Bypass Switches onto the New Brackets

Refer to [Figure 7](#) for this step of the procedure. New parts are listed in [Table 1 on page 4](#).

1. Position each new bypass switch on a new switch bracket as shown. Make sure that the switches are oriented as shown; they are not oriented the same for both ports. The A52 switch, with the longest cable, is for port 1.
2. Secure each switch to its bracket using two screws (item ①) for each.
3. Remove the source and receiver attenuators from the old bracket and, using the same screws (item ②), attach them to the new brackets. Make sure that they are oriented as shown; they are not oriented the same for both ports.
4. Secure the bias tee brackets to the attenuator brackets using two screws (item ③) for each.

Figure 7 Attenuators and Bypass Switches Assembly

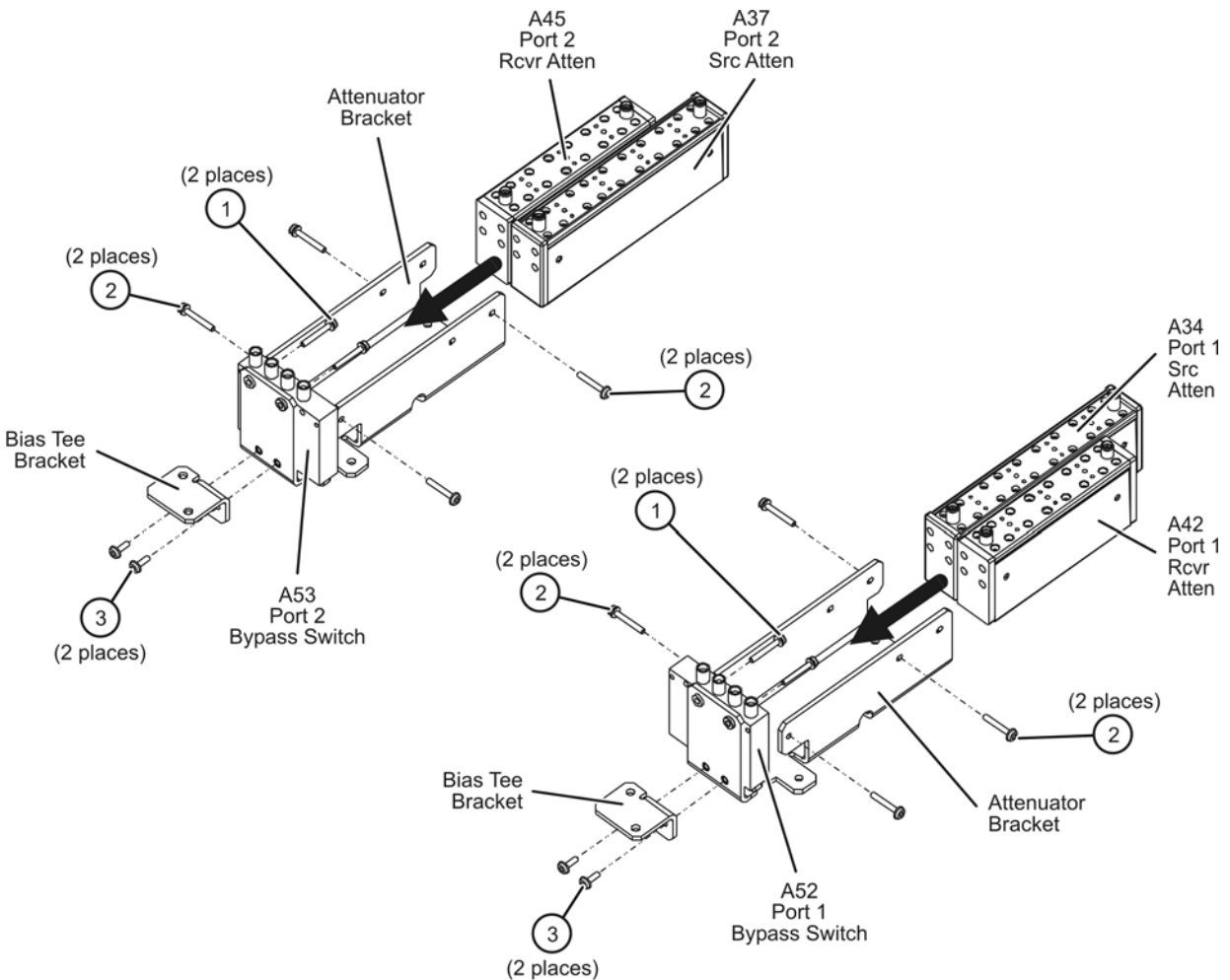

n5242_009_03

Step 8. Install the New Brackets, with the Old Attenuators and the New A52 and A53 Bypass Switches, into the Analyzer

Refer to [Figure 8](#) for this step of the procedure. Although only Option 419 is shown in the illustration, Option 423 is similar in appearance. New parts are listed in [Table 1 on page 4](#).

1. Position the attenuator brackets, with the attenuators and bypass switches attached, in the analyzer as shown. Make sure that the brackets are placed as shown; the attenuators and bypass switches are not oriented the same for both ports.
2. Secure the attenuator brackets to the analyzer test set deck using three screws (item ①) for each.

If bias tee option is installed:

3. Position the existing bias tees, with cables attached, on the new bias tee brackets and secure each of them with the original two mounting screws (item ②).
4. Reconnect cables W85, W120, and W119 to the bias tees. These cables were disconnected in “[Step 6. Remove the Existing Attenuators and Brackets](#)” on page 14.
5. Reinstall any other cables that were removed to facilitate removal of the old attenuator brackets. Do not reinstall the cables that were specified to be discarded.

Figure 8 New Brackets Installation into the Analyzer

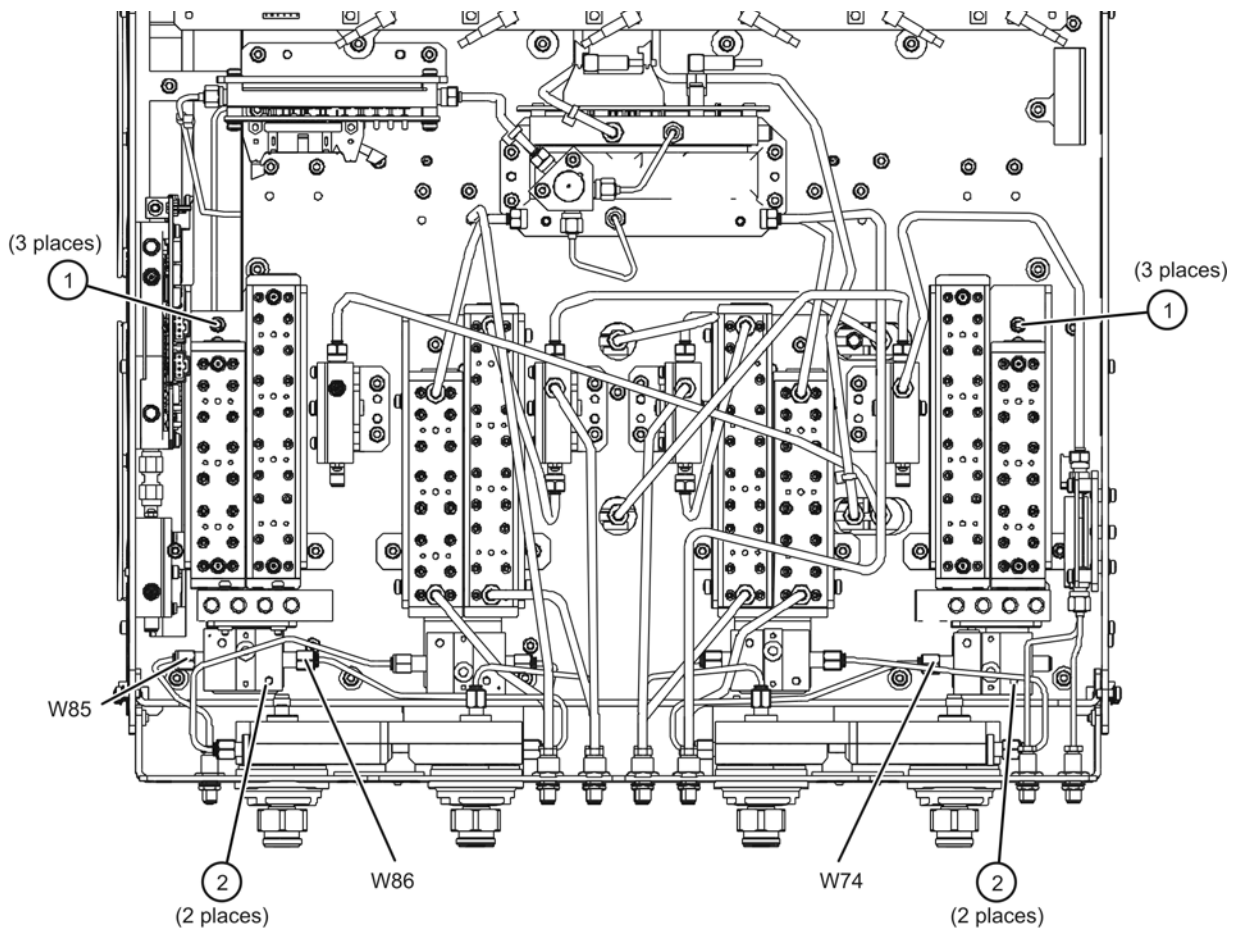

n5242_010_05

Step 9. Assemble and Install the A54 Bridge and A55 Noise Downconverter

Refer to [Figure 9](#) for this step of the procedure. New parts are listed in [Table 1 on page 4](#).

1. Connect the A54 bridge to the A55 noise downconverter, using cable adapter W131, as shown. Place these assemblies on a flat surface and torque each W131 connector to 10 in-lbs while holding the A54 and A55 assemblies flat.
2. Connect the ribbon cable (item ①) to the A55 noise downconverter connector as shown.
3. Place the combined A54/W131/A55 assembly into the analyzer as shown.
4. Secure the A55 noise downconverter to the side frame using three screws (item ②), as shown.
5. Secure the A54 bridge to the side frame using one screw (item ③) and one hex nut with lock washer (item ④), as shown. Install the screw from the outside of the side frame, through the top hole in the A54 bridge, and place the nut/washer on the inside. Hold the hex nut with a wrench while tightening the screw.

Figure 9 A54 Bridge and A55 Noise Down Converter Installation

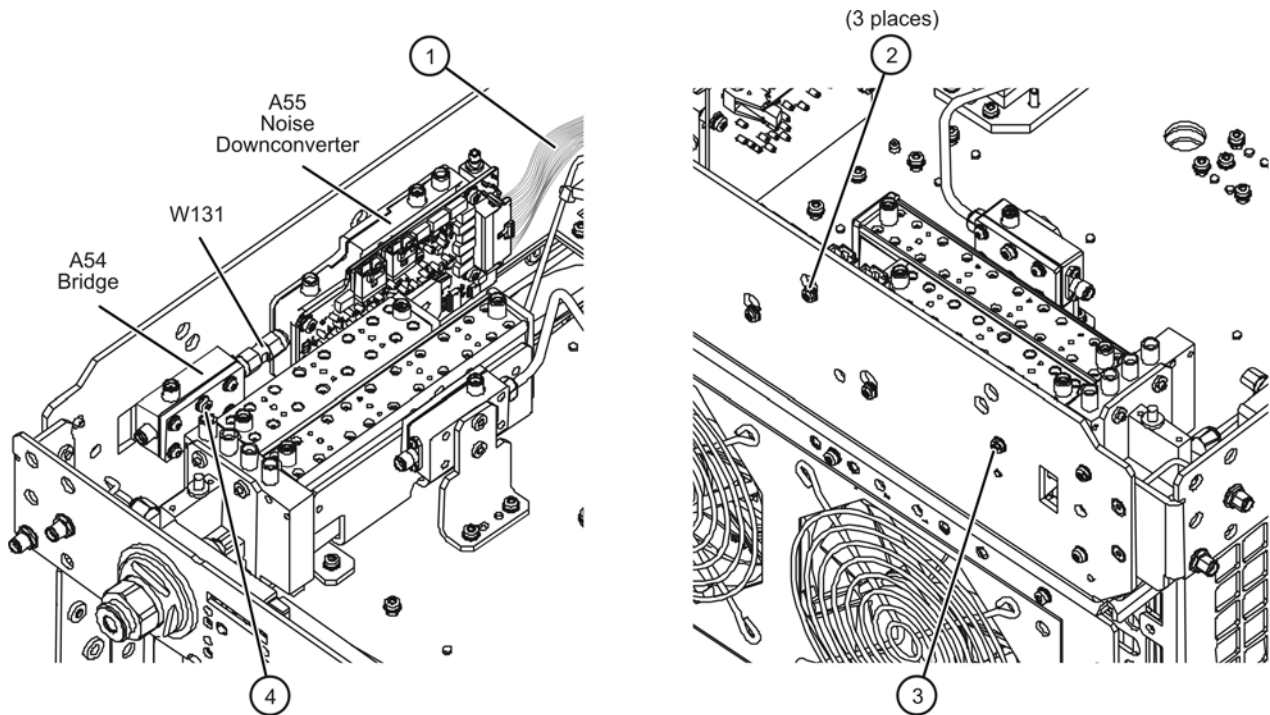

n5242_009_05

Step 10. Install the A7 Noise Receiver Board

Refer to [Figure 10](#) for this part of this step of the procedure. Although only Option 419 is shown in the illustration, Option 423 is similar in appearance. New parts are listed in [Table 1 on page 4](#).

1. Place the analyzer top-side up on a flat surface.
2. Insert the A7 noise receiver board in the analyzer as shown. Make sure it is fully seated in the motherboard connector.

Figure 10 Noise Receiver Board Installation

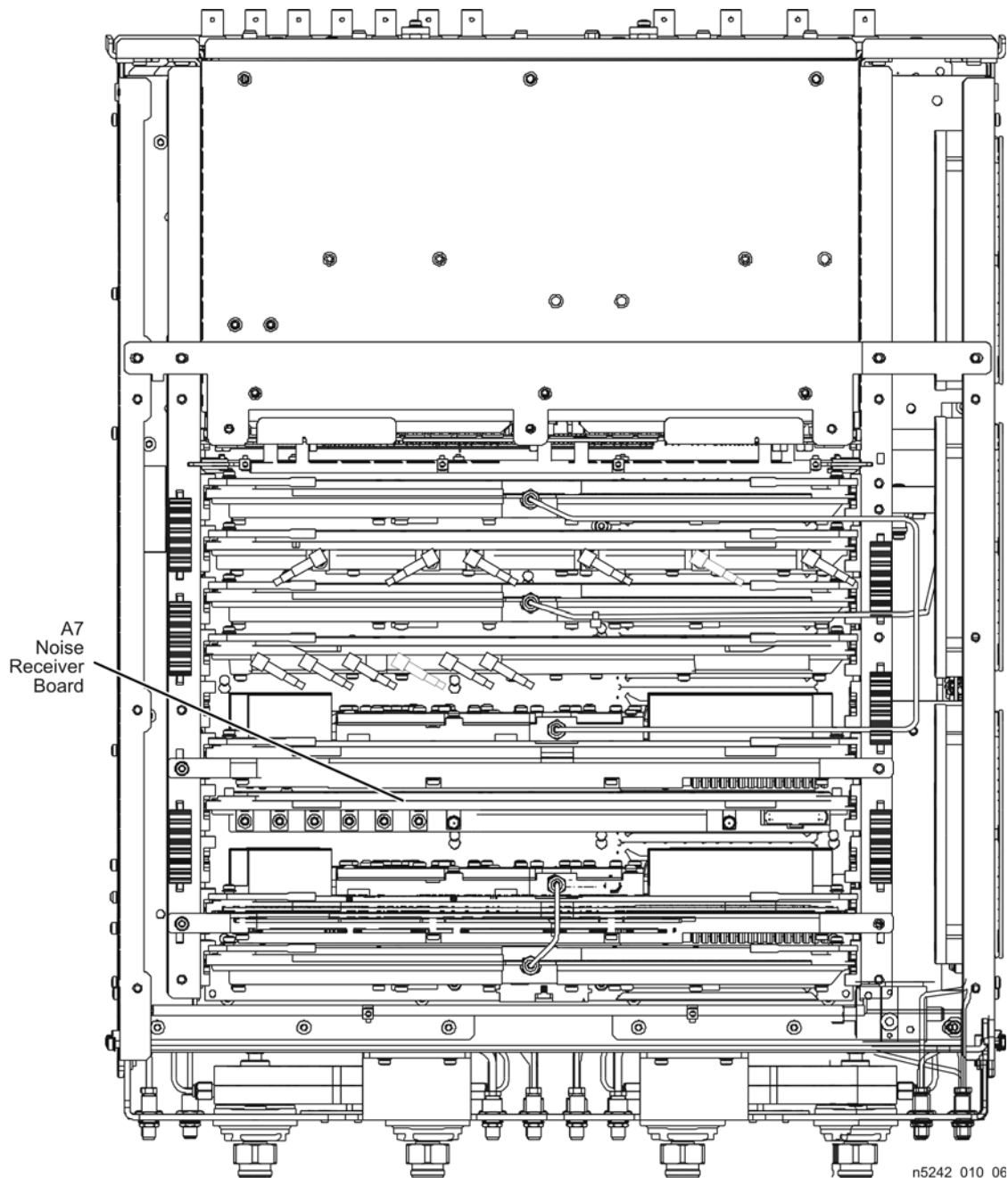

Step 11. Install the New Test Set Cables

Refer to [Figure 11](#) and [Figure 12](#) for this step of the procedure. Although only Option 419 is shown in the illustrations, Option 423 is similar in appearance. New parts are listed in [Table 1 on page 4](#).

1. Connect the following wire harness and ribbon cables:
 - ①—A42 port 1 receiver attenuator to A19 test set motherboard J205
 - ②—A34 port 1 source attenuator to A19 test set motherboard J201
 - ③—A45 port 2 receiver attenuator to A19 test set motherboard J208
 - ④—A37 port 2 source attenuator to A19 test set motherboard J204
 - ⑤—A53 port 2 bridge to A55 noise downconverter J11
 - ⑥—A52 port 1 bridge to A55 noise downconverter J10
 - ⑦—A55 noise downconverter J1 to A19 test set motherboard J548
2. Install the following semirigid cables in the order listed. Use a 5/16-in torque wrench set to 10 in-lbs to tighten all cable connectors.
 - W26 A32 port 2 coupler to front-panel Port 2 CPLR ARM
 - W135 Front-panel Port 2 RCVR B IN to A45 port 2 receiver attenuator
 - W128 A53 port 2 bypass switch to front-panel Port 2 SOURCE OUT
 - W127 A37 port 2 source attenuator to A53 port 2 bypass switch
 - W130 A53 port 2 bypass switch to A54 port 2 bridge
 - W129 A53 port 2 bypass switch to A54 port 2 bridge

If bias tee option is installed:

- W125 A52 port 1 bypass switch to A38 port 1 bypass tee

If bias tee option is not installed:

- W152 A52 port 1 bypass switch to A29 port 1 coupler
- W14 A29 port 1 coupler to front-panel Port 1 CPLR ARM
- W132 Front-panel Port 1 RCVR A IN to A42 port 1 receiver attenuator
- W124 Front-panel Port 1 CPLR THRU to A52 port 1 bypass switch
- W123 A52 port 1 bypass switch to front-panel Port 1 SOURCE OUT
- W122 A34 port 1 source attenuator to A52 port 1 bypass switch
- W126 A28 port 2 bridge to A37 port 2 source attenuator
- W137 A28 port 2 bridge to front-panel REF 2 SOURCE OUT
- W121 A25 port 1 bridge to A34 port 1 source attenuator
- W136 A33 reference mixer switch to A23 mixer brick (R1)
- W133 A42 port 1 receiver attenuator to A23 mixer brick (A)

- W134A45 port 2 receiver attenuator to A23 mixer brick (B)
 - W138Front-panel REF 2 RCVR R2 IN to A23 mixer brick (R2)
 - W140A24 mixer brick to A55 noise downconverter
3. Position the analyzer as shown in [Figure 12 on page 22](#) (fans facing upwards) and loosely install the following cables. Route each of the cables through the opening in the test set deck to the top side of the analyzer. The other ends will be connected in the next step.
- W143 Semirigid cable, A55 noise downconverter to A7 noise receiver board RF
 - W141 Semirigid cable, A55 noise downconverter to A7 noise receiver board LO
 - W142 Flexible cable, A55 noise downconverter J4 to A7 noise receiver board P2

Figure 11 New Test Set Cable Installation, Part 1

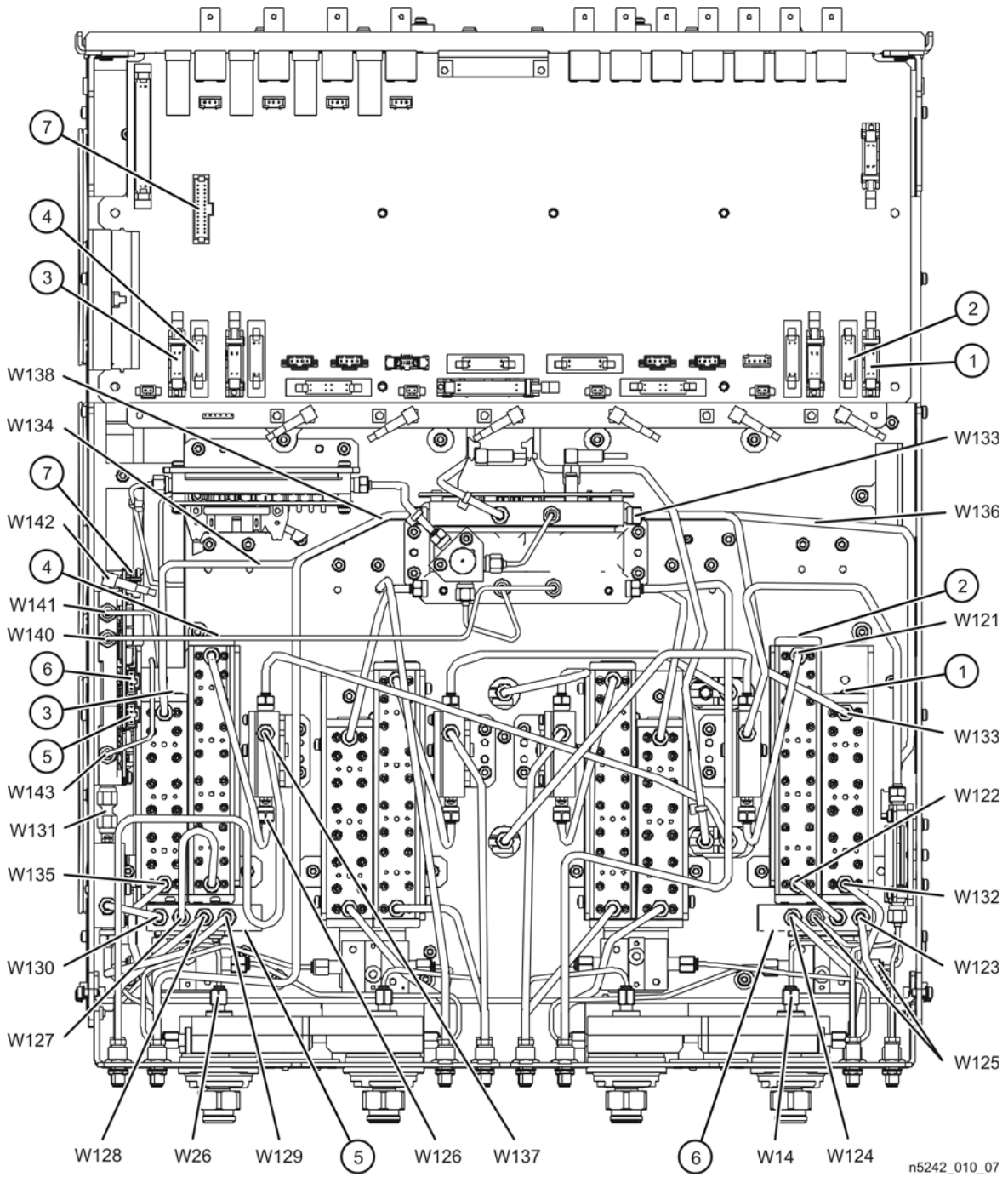

Refer to [Figure 12](#) for this part of this step of the procedure. Although only Option 419 is shown in the illustration, Option 423 is similar in appearance. New parts are listed in [Table 1 on page 4](#).

4. The analyzer should be positioned on its left side (fans facing upwards) as shown.
5. Connect semirigid cables W141 and W143 as indicated. Torque connectors to 10 in-lbs.
6. Connect flexible cable W142 as indicated.
7. Go back and torque the connectors on the other ends of W141 and W143 to 10 in-lbs.

Figure 12 New Test Set Cable Installation, Part 2

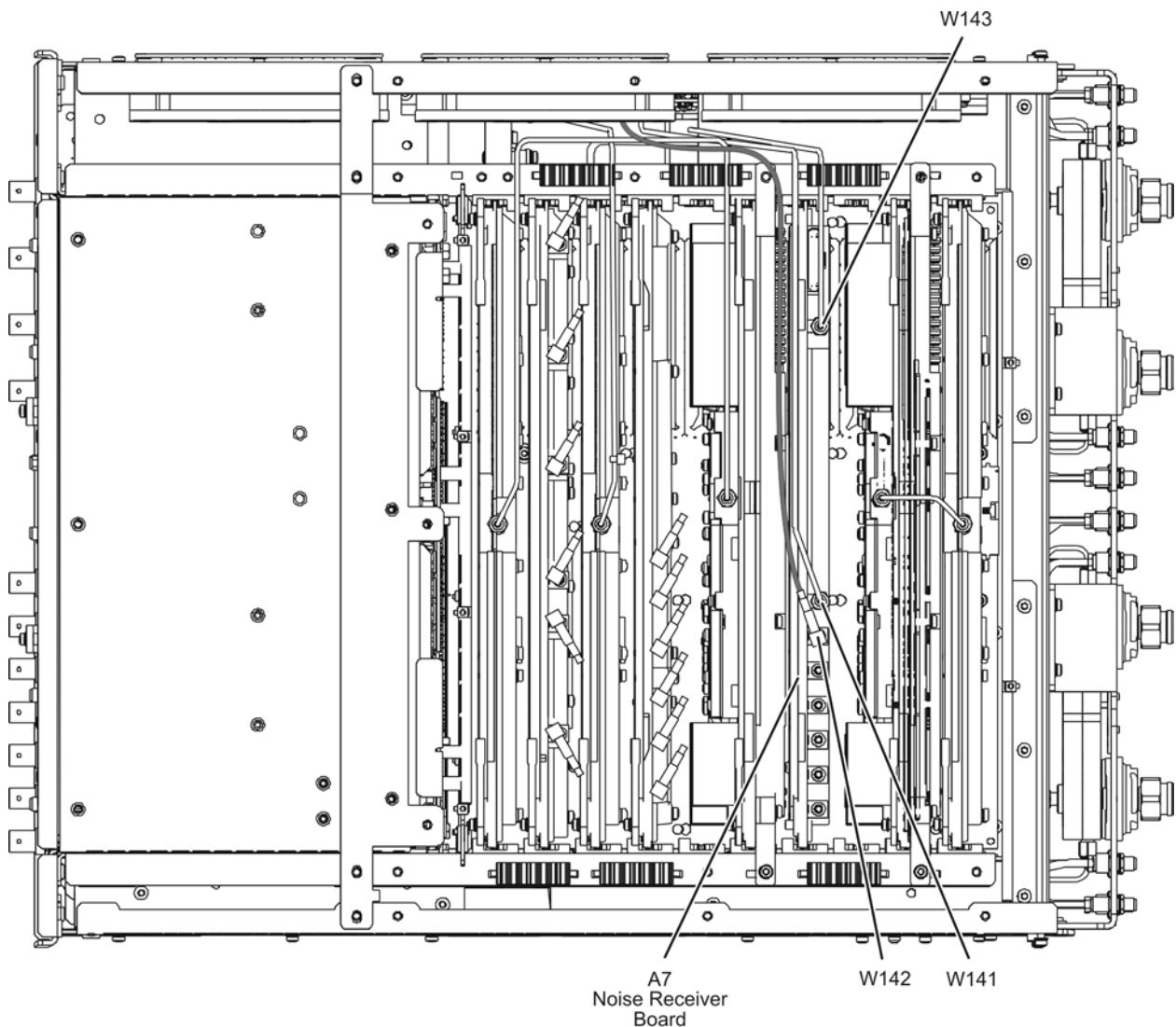

n5242_010_08

Step 12. Replace the A16 Power Supply (If Necessary)

Refer to [Figure 13](#) for this step of the procedure. The analyzer model shown in the illustration is for reference only and may not be the same as your analyzer. New parts are listed in [Table 1 on page 4](#).

1. Check the part number of the power supply currently installed in your analyzer. If the correct power supply is installed, you need not replace it.
 - a. The part number should be as shown in [Table 1 on page 4](#).
 - b. If the part number IS as shown, proceed to “[Step 13. Replace the Lower Front Panel Overlay](#)”.
 - c. If the part number IS NOT as show, continue with this step.
2. Remove the three flat head screws (item ①) from the power supply bracket.
3. Remove the seven pan head screws (item ②) from the power supply rear panel.
4. Slide the A16 power supply assembly out the rear of the analyzer.
5. Slide the new A16 power supply assembly into position in the analyzer.
6. Reinstall the seven pan head screws (item ②) in the power supply rear panel.
7. Reinstall the three flat head screws (item ①) in the power supply bracket.

Figure 13 Power Supply Replacement

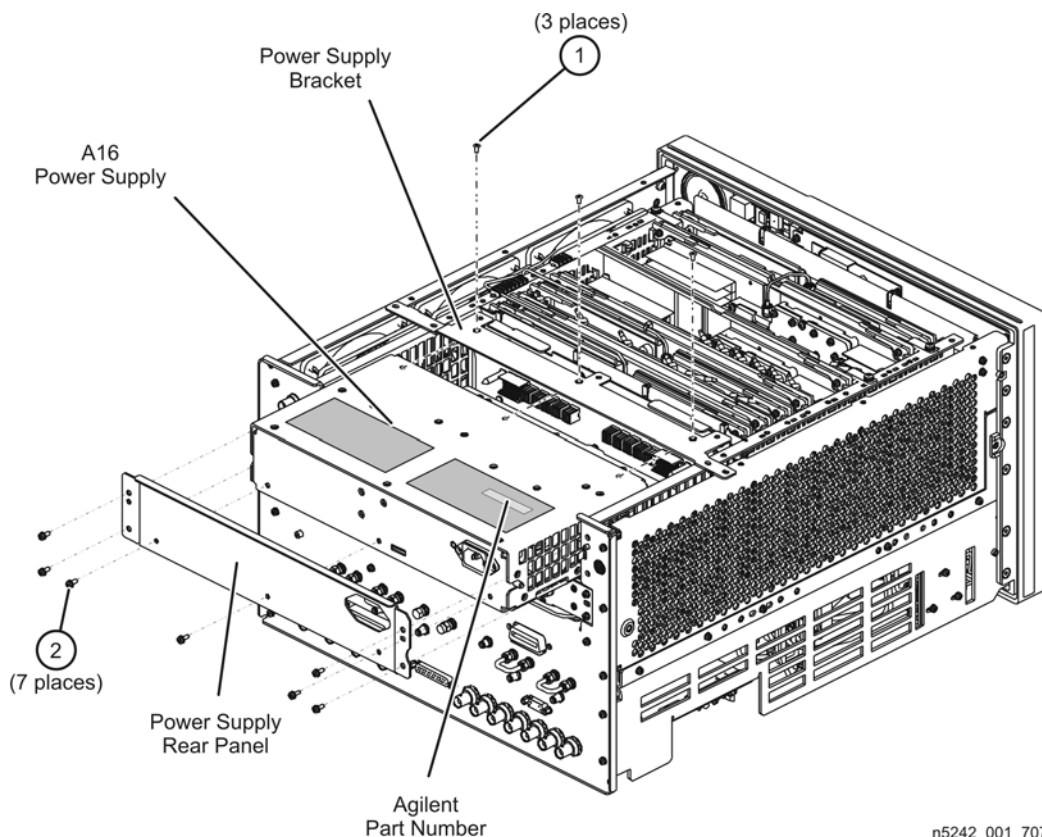

n5242_001_707

Step 13. Replace the Lower Front Panel Overlay

Refer to [Figure 13](#) for this step of the procedure. New parts are listed in [Table 1 on page 4](#).

1. From the back side of the front panel, use a blunt object in the cutouts in the lower front dress panel to push on the old overlay (item ①) and separate it from the front dress panel.
2. From the front side of the front panel, pull off the overlay completely and discard it.
3. Remove any adhesive remaining on the front panel.
4. Remove the protective backing from the new front panel overlay (item ②).
5. Starting from either side, *loosely* place the overlay in the recess on the lower front panel, ensuring that it fits tightly against the edges of the recess.
6. Once the overlay is in place, press it firmly onto the frame to secure it.

Figure 14 Lower Front Panel Overlay Replacement

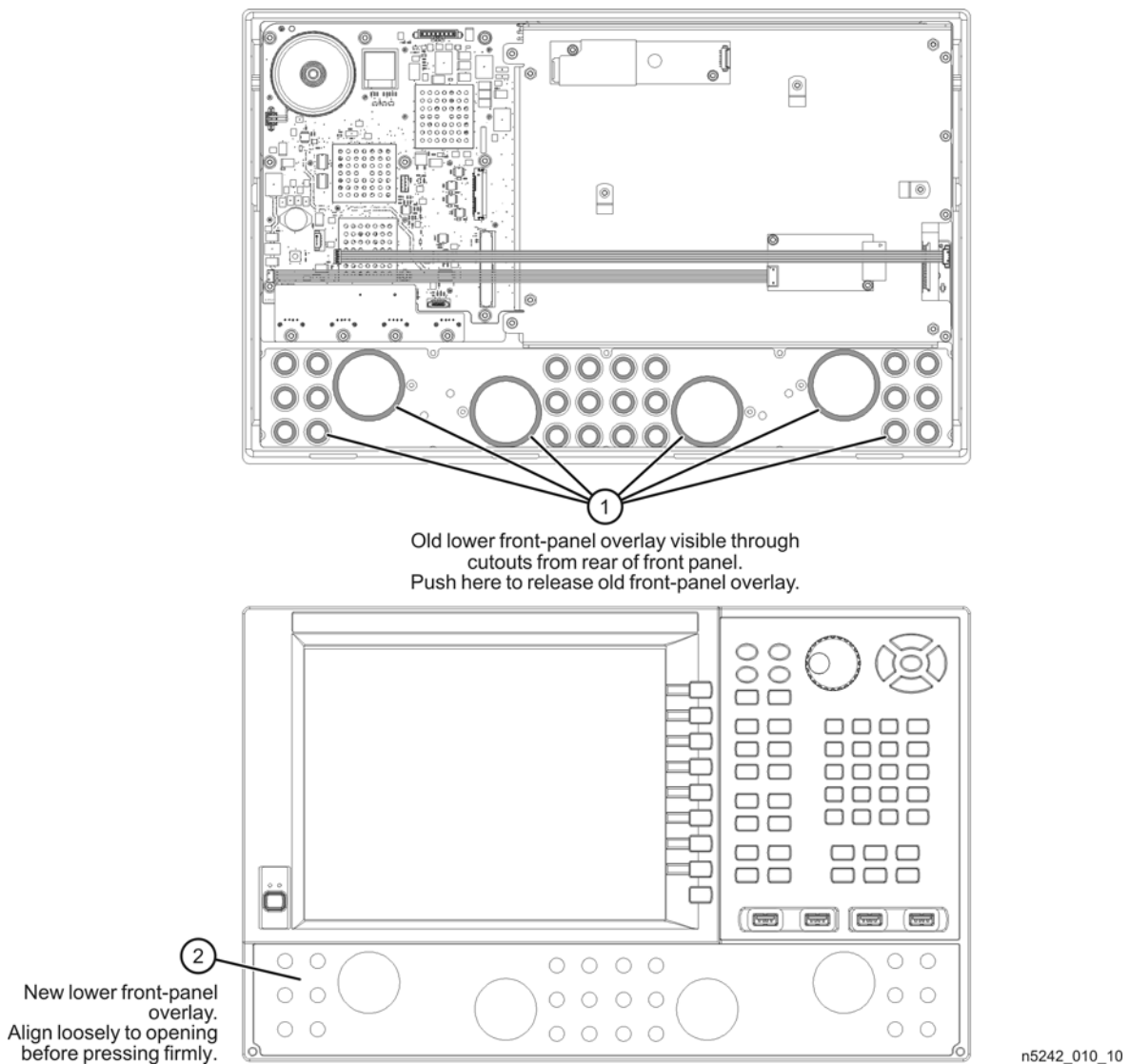

Step 14. Reinstall the Front Panel Assembly and Front Panel Jumpers

CAUTION Before installing the front panel assembly onto the analyzer, lift and support the front of the analyzer chassis.

Refer to [Figure 15](#) for this step of the procedure. New parts are listed in [Table 1 on page 4](#).

1. Make sure all of the hex nuts on the front-panel cable connectors have been tightened using a 5/16-in torque wrench set to 21-in lbs.
2. Reconnect the ribbon cable (item ③) to the A1 front panel interface board.
3. Slide the front panel over the front-panel connectors.
4. With a T-10 TORX driver, reinstall the 12 screws (item ②) in the sides of the frame.
5. Reinstall the semirigid jumpers (item ①) on the front panel, and tighten each of the connectors to 10-in lbs.

Figure 15 Front Panel Assembly Reinstallation

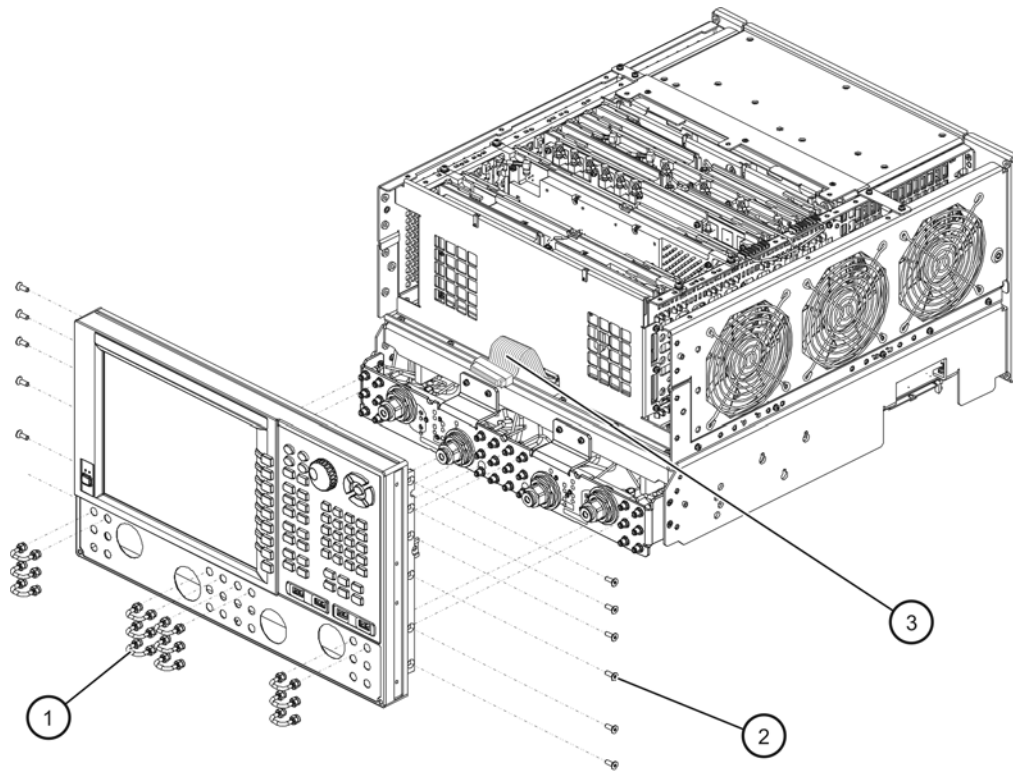

n5242_010_02

Step 15. Reinstall the Inner Cover

Refer to [Figure 16](#) for this step of the procedure.

1. Position the inner cover on the analyzer.
2. With a T-10 TORX driver, install the 12 pan head screws (item ①).
3. With a T-10 TORX driver, install the 9 flat head screws (item ②).

Figure 16 Inner Cover Reinstallation

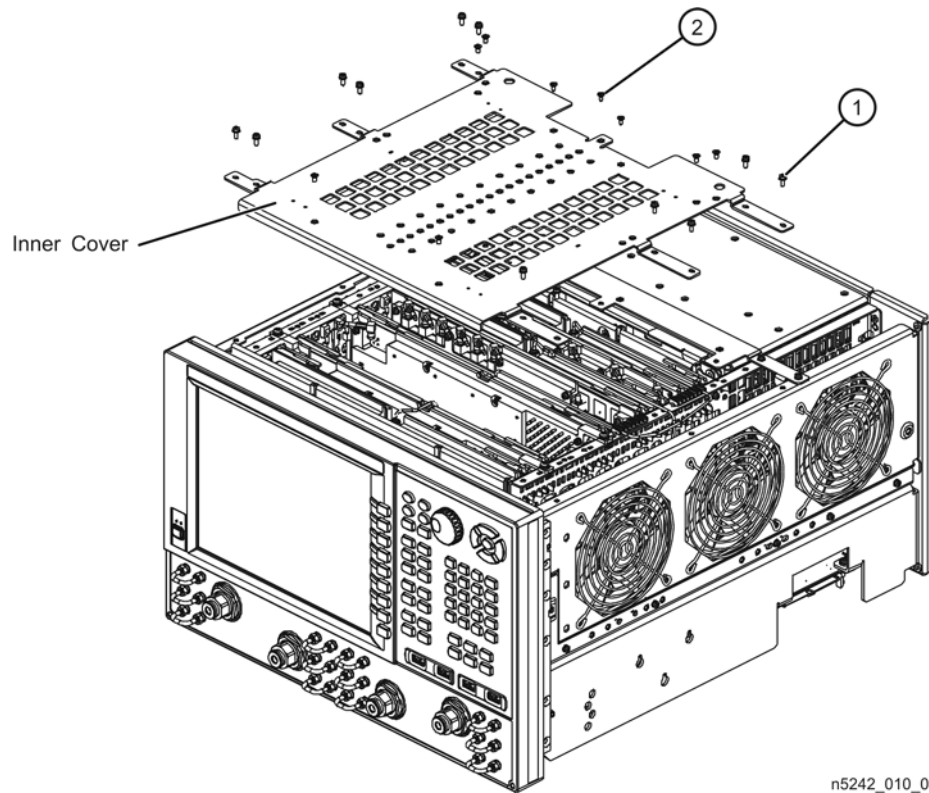

Step 16. Reinstall the Outer Cover

CAUTION This procedure is best performed with the analyzer resting on its front handles in the vertical position. *Do not place the analyzer on its front panel without the handles.* This will damage the front panel assemblies.

Refer to [Figure 17](#) for this step of the procedure.

1. Slide the outer cover over the analyzer frame.
2. Install the four rear panel feet (item ⑤) by installing the center screws (item ⑥) with a T-20 TORX driver.
3. Install the four bottom feet (item ④) onto the bottom of the outer cover then install the foot locks (item ③).
4. Install the strap handles (item ①) by tightening the screws (item ②) on both ends of each strap handle with a T-20 TORX driver.

Figure 17 Outer Cover Reinstallation

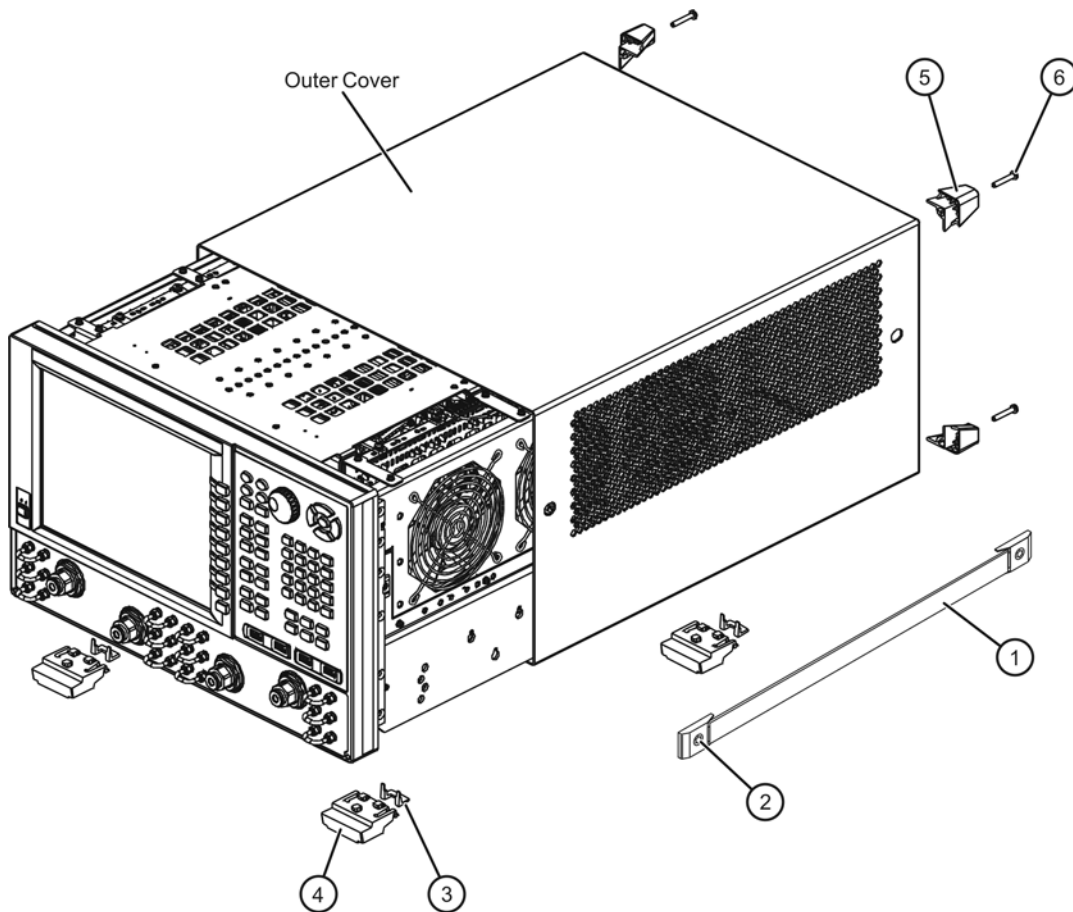

n5242_004_01

Step 17. Enable Option 029

Procedure Requirements

- The analyzer must be powered up and operating to perform this procedure.
- The Network Analyzer program must be running.
- A keyboard must be connected to the network analyzer.

Option Enable Procedure

NOTE: You must have a keyword to enable this option. If you have not yet obtained the necessary keyword, refer to [“Step 1: Obtain a Keyword” on page 8](#) for instructions.

1. To start the option enable utility, press UTILITY **System**, then **Service**, then **Option Enable**. An option enable dialog box will appear.
2. Click the arrow in the **Select Desired Option** box. A list of available options will appear.
3. In the **Select Desired Option** list, click **029 - Full Noise Measurements**.
4. Using the keyboard, enter the keyword you obtained, in the box provided. Enter this keyword *exactly* as provided.
5. Click **Enable**.
6. Click **Yes** in answer to the displayed question in the **Restart Analyzer?** box.
7. When the installation is complete, click **Exit**.

Option Verification Procedure

Once the analyzer has restarted and the Network Analyzer program is again running:

1. On the analyzer’s **Help** menu, click **About Network Analyzer**.
2. Verify that “029” is listed after “Options:” in the display. Click **OK**.

NOTE If Option 029 has not been enabled, perform the [“Option Enable Procedure”](#) again. If the option is still not enabled, contact Agilent Technologies. Refer to [“Getting Assistance from Agilent” on page 3](#).

Step 18. Perform Post-Upgrade Adjustments and Calibration

Adjustments

The following adjustments must be made due to the hardware changes of the analyzer.

- source adjustment
- receiver adjustment
- noise figure adjustment

These adjustments are described in the PNA Service Guide and in the PNA on-line HELP. A list of equipment required to perform these adjustments is also found in the service guide.

To view the Service Guide online, use the following steps:

1. Go to www.agilent.com.
2. In the Search box, enter the model number of your analyzer, N5242A, and click **Search**.
3. Click [Technical Support > Manuals](#).
4. Click [Service Manual](#).
5. Click the service guide title to load the PDF file.
6. When the PDF of the Service Guide is displayed, scroll through the Contents section bookmarks to locate the “Tests & Adjustments” chapter.

After the specified adjustments have been performed, the analyzer should operate and phase lock over its entire frequency range.

Operator’s Check

Perform the Operator’s Check to check the basic functionality of the analyzer. For instructions, refer to the “Tests & Adjustments” chapter of the Service Guide.

If you experience difficulty with the basic functioning of the analyzer, contact Agilent. Refer to [“Contacting Agilent” on page 3](#).

Calibration

Although the analyzer functions, its performance relative to its specifications has not been verified. It is recommended that a full instrument calibration be performed using the analyzer’s internal performance test software. Refer to the analyzer’s service guide for information on this performance test software.

